

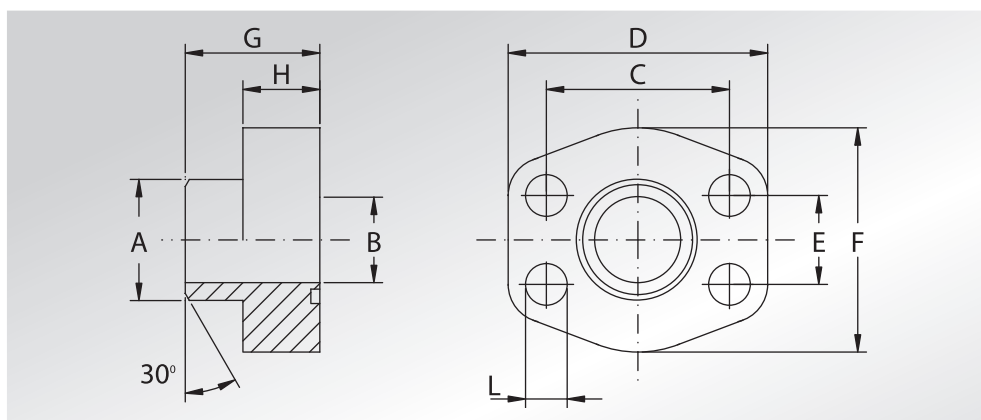

FLANGE A SALDARE DI TESTA SCH.XXS

WELD ON FLANGES SCH.XXS



Pressione max di esercizio raccomandata Kg/cm ²	Grandezza	Tipo	Dimensioni									Viti		Or tipo	Peso Kg
Maximum recommended working pressure Kg/cm ²	Size	Type	Dimensions									Screws		Or type	Weight Kg
			A	B	C	D	E	F	G	H	L	Metric	Unc		

SERIE 3000

345	1/2"	AFS080STB6	21,5	6,3	38,10	57	17,48	46	36	16	9	M8x30	5/16x1"1/4	4075	0,24
345	3/4"	AFS100STB11	28,0	11,0	47,63	65	22,23	50	36	18	11	M10x35	3/8x1"1/2	4100	0,35
345	1"	AFS102STB15	34,0	15,2	52,37	70	26,19	55	38	18	11	M10x35	3/8x1"1/2	4131	0,41
276	1"1/4	AFS104STB22	42,8	22,8	58,72	79	30,18	68	41	21	11,5	M10x40	7/16x1"3/4	4150	0,64
207	1"1/2	AFS106STB28	48,6	28,0	69,85	93	35,71	78	44	25	13,5	M12x45	1/2x1"3/4	4187	0,98
207	2"	AFS108STB38	61,0	38,2	77,77	102	42,88	90	45	25	13,5	M12x45	1/2x1"3/4	4225	1,14
172	2"1/2	AFS110STB45	77,0	45,0	88,90	114	50,80	105	50	25	13,5	M12x45	1/2x1"3/4	4275	1,55
138	3"	AFS112STB58	92,0	58,4	106,38	134	61,93	124	50	27	17,5	M16x50	5/8x2"	4337	2,33
138	4"	AFS116STB80	115,5	80,0	130,18	162	77,77	146	48	27	17,5	M16x50	5/8x2"	4437	2,85
138	5"	AFS118STB102 (•)	140,2	102,9	152,40	184	92,08	180	50	28	17,5	M16x50	5/8x2"	4537	3,60

SERIE 6000

414	1/2"	AFS401ST012B6	21,5	6,3	40,49	57	18,24	46	36	16	9	M8x30	5/16x1"1/4	4075	0,24
414	3/4"	AFS402STB11	28,0	11,0	50,80	71	23,80	55	35	21	11	M10x40	3/8x1"1/2	4100	0,48
414	1"	AFS403STB15	34,0	15,2	57,15	79	27,76	68	41	21	13	M12x45	7/16x1"3/4	4131	0,64
414	1"1/4	AFS404STB22	42,8	22,8	66,68	93	31,75	78	44	25	15 *	M14x45	1/2x1"3/4	4150	1,00
414	1"1/2	AFS405STB28	48,6	28,0	79,38	112	36,50	94	55	28	17	M16x50	5/8x2"	4187	1,68
414	2"	AFS406STB38	61,0	38,2	96,82	134	44,45	114	65	37	21	M20x70	3/4x2"1/2	4225	2,86
414	2"1/2	AFS507STB45	76,6	45,0	123,80	180	58,70	152	80	45	26	M24x80	-	4275	6,40
414	3"	AFS508STB58	90,0	58,4	152,40	208	71,40	178	90	55	33	M30x100	-	4337	-

PER QUESTA TIPOLOGIA DI PRODOTTO, VERIFICATE SEMPRE SE LA QUOTA "A" E "B" CORRISPONDE ALLA SCHEDULA DEL VOSTRO TUBO

FOR THIS KIND OF PRODUCT, PLEASE ALWAYS VERIFY IF DIMENSION "A" AND "B" CORRESPOND TO THE SCHEDULE OF YOUR TUBE

DESIGNAZIONE PER ORDINE DESIGNATION FOR ORDER	Materiale / Material	
	ST52.3	AISI 316L
Solo flangia Only flange	AFS...STB	AFX...STB
Flangia completa di viti metriche, grower e o-ring Flange complete of metric screws, grower type washers and o-ring	AFS...STB...M	AFX...STB...M
Flangia completa di viti unc, grower e o-ring Flange complete of unc screws, grower type washers and o-ring	AFS...STB...U	AFX...STB...U

NOTE / NOTES

* Per viti unc L=13,5
* For unc screws L=13,5

(•) Solo in ST52.3
(•) Only in ST52.3

set viti unc disponibili solo in acciaio al carbonio.
unc screws set available only in carbon steel.